



HARLEY-DAVIDSON UNIVERSITY

**TECHNICAL FORUM**

2007 MODEL YEAR



# ALL MODELS

## NEW Smart Security System Option

- Hands/button-free security key fob
- System arms itself within five seconds of turning ignition "off," and disarms when ignition is turned on or motorcycle is moved with fob present
- Security system is "transparent" to the customer
- Attempts to move the motorcycle with fob on the seat or within 4 in. from antenna could activate the system



- Harley-Davidson® Smart Security System impacts:
  - PDI process
  - Service Writers and Sales
  - Transportation of motorcycle
  - Servicing of motorcycle
  - Customer expectations
- Storage mode eliminated; current draw drops from 3.2 mA to .7 mA
- P&A siren upgrades system with chirp disable feature
- HDI motorcycles, excluding Japan, feature OE siren-equipped security systems

### Important Service Note:

Fob requires serial # assignment with DT, and PIN # must be entered before fob assignment.



## NEW Speedometers, Tachometers and Indicators (except VRSC™)

- Similar features as the 2006 VRSC™ models
- Clock function
- 6th Gear indicator for Big Twin motorcycles
- Dual trip meters
- Retrofit gauges (suffix change)
- P&A tachometer output signal on 4 in. speedometer
- Lower standby current
- UK dual-face speedometers change to 130 mph (200 km/h)



## Clock Function

- Displayed on LCD (odometer window)
- Selected with trip switch button (press release)
- Set with trip switch button (press hold/press release)
- 12/24-Hour selectable

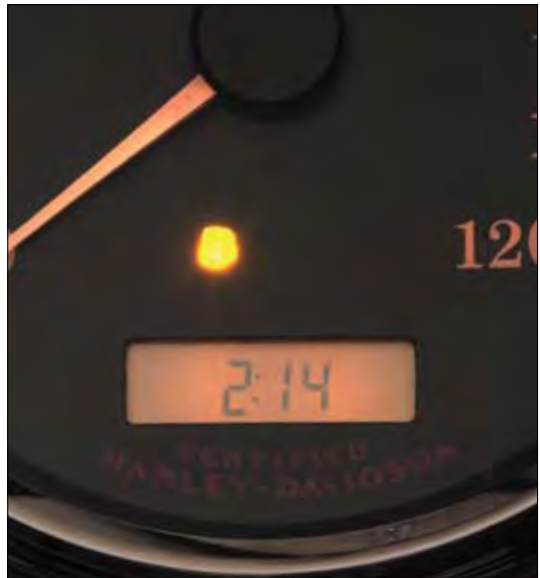

## NEW LED Indicators (except VRSC™)

---

- Easier-to-read LED indicators replace incandescent bulbs

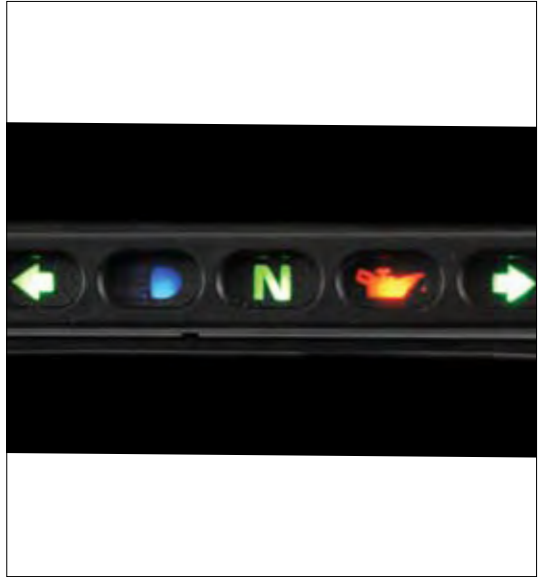

## Reduced-Effort Clutch Cable

---

- 2006 Dyna™ design
- New clutch cable
- Reduced-effort clutch lever:
  - 8% Reduction for Sportster® models
  - 10% Reduction for Softail® models
  - 7% Reduction for Touring models



## Clutch Interlock Switch

---

- Clutch interlock switch functions as an “or” function with the neutral switch
- Switch verifies if the motorcycle is in neutral and if not, the clutch lever must be disengaged (pulled in) before motorcycle will start
- Excellent feature for new riders



## Electronic Sequential Port Fuel Injection (E.S.P.F.I.)

---

- Similar design was incorporated for the 2006 Dyna™ models
- O<sub>2</sub> feedback system eliminates the need for catalyts (except VRSC™ models)
- HDI motorcycles are equipped with O<sub>2</sub> sensor feedback
- System adjusts to provide optimal air/fuel mixture
- Some CVO motorcycles require catalyts



## NEW Molex® Connectors (except Buell®)

- Molex® connectors are smaller than Deutsch® connectors
- Molex® connectors are internally sealed from moisture



- VRSC™ models feature Molex® connectors exclusively
- Connector is only serviced from the mated side



Molex is a registered trademark of Molex Products Company.

## Final Drive Belt

- 1 in. wide X7N belt
- Second generation carbon fiber
- Thicker fabric for increased tooth strength and wear resistance
- Touring models receive a 137T belt
- H-D Japan Touring models receive a 136T belt

### Important Service Note:

New belt tension specifications for all models.

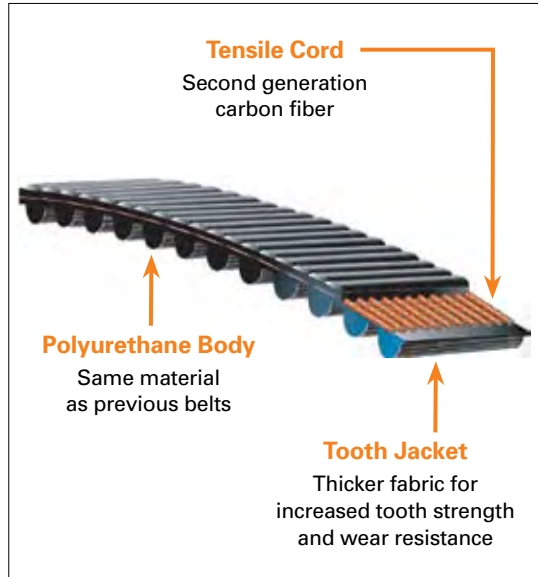





# BIG TWIN ENGINES

## **NEW Twin Cam 96™ Engine Powertrain Specifications**

- Displacement:  
96 cu. in. 1584 cc up  
from 88 in. 1450 cc
  - Achieved by stroke  
increase to 4.375 in.  
(111.13)
- Touring Alpha engines  
have increased torque  
to 93 ft. lbs. (126 NM)  
@ 3500 rpm



- Softail® Beta engines  
have increased torque  
to 90 ft. lbs. (122 NM)  
@ 2750 rpm
- Dyna™ Alpha engines  
have increased torque  
to 92 ft. lbs. (125 NM)  
@ 3000 rpm



## Twin Cam 96™ Connecting Rods and Pistons

---

- Lighter pistons and connecting rods for lower reciprocating weight
- Shorter wrist pin



---

## 25-Degree Injectors

---

- 2006 running change to 25-degree fuel injectors (P/N H-D-27709-06A)



## Twin Cam 96™ Components Follow 2006 Dyna™ Powertrain

- Compensator assembly/alternators
  - Four spring pack design for domestic and HDI models
  - Compensator spring pack now welded to rotor



- Twin Cam 96™ Alpha engine/transmission gasket



## Twin Cam 96™ Components Follow 2006 Dyna™ Powertrain (cont.)

---

- Engine cases with integral oil filter adapter



- External oil lines have been eliminated for Dyna™ and Touring Big Twin engines
- Softail® engines continue with external oil lines



**Twin Cam 96™ Components  
Follow 2006  
Dyna™ Powertrain (cont.)**

---

- Cam plate changes
  - Primary hydraulic cam chain tensioner



- Cam plate changes
  - Secondary hydraulic cam chain tensioner



## Twin Cam 96™ Components Follow 2006 Dyna™ Powertrain (cont.)

---

- Cam plate changes
  - Cam plate uses parent material bearings



- Crankshaft assembly and cases
  - Inner cam bearings



## Twin Cam 96™ Components Follow 2006 Dyna™ Powertrain (cont.)

---

- Assembled cams



- Oil pump assembly
  - 10% More flow and 23% scavenging capacity improvement
  - O-ring between oil pump and cam support plate has been eliminated
  - 10/11 Lobe gerotor set





## Twin Cam 96™ Components Follow 2006 Dyna™ Powertrain (cont.)

- Dyna™-style roller cam chains
  - All Big Twin models feature hydraulic chain tensioners and new cam chains



- Flywheel sprocket shaft splines match 2006 Dyna™ models



## Twin Cam 96™ Components Follow 2006 Dyna™ Powertrain (cont.)

- 6-Speed Cruise Drive™ transmission
- 6th Gear is direct drive 1:1
- Lower cruising rpm in 6th gear is achieved with new primary ratio
- 2nd, 3rd, 4th and 6th are helical gears
- 1st and 5th are spur gears
- 1st, 2nd, 3rd and 4th gears are integral on mainshaft



- 5th and 6th gears are integral on countershaft
- Six of 12 gears are individually serviceable
- Christmas tree gear layout on shafts
- VRSC™-style dog ring shifting
- XL/XB-style shifter design



## Twin Cam 96™ Components Follow 2006 Dyna™ Powertrain (cont.)

- 6th Main drive gear
- Quad-ring replaced by O-ring on new main drive gear
- Needle bearings for 6th gear mainshaft
- Needle bearings secured by retaining rings
- Double-row output bearing
- Sprocket spacer incorporated into bearing



- Primary drive system
- Drive ratio is 1.35:1
- Dyna™ clutch shell
- Starter ring gear moved to inboard on clutch hub



**Twin Cam 96™ Components  
Follow 2006  
Dyna™ Powertrain** (cont.)

---

- Automatic mechanical primary chain tensioner



- New inner primary housings
- Inner primary must be removed to service rotor and stator



**Twin Cam 96™ Components  
Follow 2006  
Dyna™ Powertrain** (cont.)

---

- Primary gasket/fasteners



- Primary chain inspection cover has been removed



## 6th Gear Indicator

- Lamp activates during motorcycle operation in 6th gear
- Vehicle speed and engine rpm determine light activation; not a switch

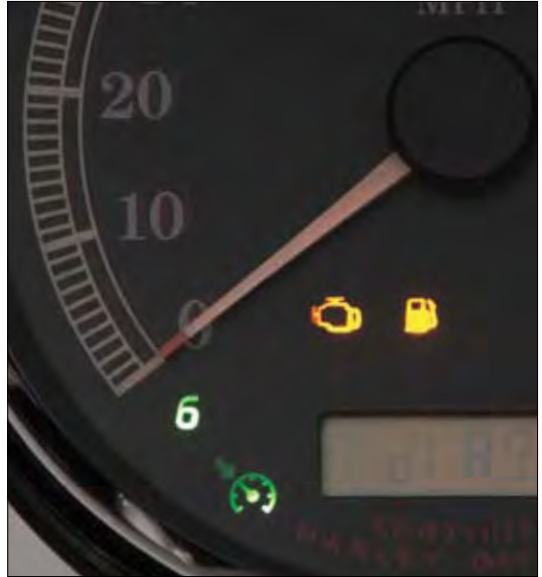

## Charging System

- Softail® and Dyna™ models feature a new 40-amp alternator



**NEW One-Piece Horn Cover**

- For ease of assembly



**OE Exhaust**

- Improved sound quality



### HDI Only - Active Intake

---

- Solenoid controls the opening and closing of baffle in the air cleaner backing plate to reduce intake noise
- H-D Japan motorcycles do not feature active intake



- Solenoid attached to backside of air cleaner backing plate





## HDI Active Exhaust

(except Japan)

- Actuator closes valve in the exhaust system during higher engine loads
- Optimizes power while meeting noise regulations
- Composite cable mount and cable are sold as a kit



### Important Service Note:

Never move the actuator by hand (or with a tool).

Actuator cannot be dropped or it will need replacement.

Active exhaust systems are to be "replace only" service items, no repairs.



## Twin Cam 96B™ Balanced Engine

- New 1584 cc Twin Cam 96B™ balanced engine
- 6-Speed Cruise Drive™ transmission is part of this powertrain



## Twin Cam 96B™ Balancers

- New balancer is first pressed into bearing
- A new tool shown here to press assembly





# VRSC™ FAMILY

## NEW Brake Pads on VRSC™ Models

- New brake pad material
- Reduced brake noise
- Reduced rotor wear
- Brake pads retrofit to 2006 models



## Two-Piece Rear Caliper Assembly

- New brake lines
- Two-piece assembly is easier to service
- VRSCR rear caliper unchanged

### Important Service Note:

Rotor does not need to be removed during tire changes.



### **NEW Fuel Sending Unit for All VRSC™ Models**

---

- Ultrasonic sending unit reads fuel levels via sound waves that reflect off the fuel level
- Fuel lines/connectors are easier to service
- Fuel line routing
- Does not retrofit



### **NEW Fuel Tank on VRSCA, VRSCD, VRSCDX and VRSCX Models**

---

- Five-gallon fuel tank for new frame
- Does not retrofit



### **VRSCDX Night Rod™ Special**

- Black-finished cam covers, alternator and clutch covers
- Blacked-out triple trees and fork lowers
- Black slotted wheels with Orange pin stripe
- Smoked turn signal lenses
- Forward controls



- 240 mm rear tire
- Wide rear fender
- New rear axle
- Lowered rear shocks
- Lowest ride height (25.2 in.) to date



## Frame Change

---

- New seat pan assembly
- VRSCA/VRSCD frame accommodates new five-gallon fuel tank
- Ignition switch moved to right front side



- Passenger footpegs relocated to frame



## NEW Coolant Tank

- Coolant tank relocated
- VRSCR coolant tank remains unchanged



## 240 mm Rear Tire Standard on New VRSCDX, VRSCX and VRSCAW Models

- Night Rod™ Special VRSCDX
- VRSCAW is a Wide version of the VRSCA from prior model years
- High-powered VRSCX
- Wide rear fenders
- New license plate bracket and inner fender
- Wide swingarm





## VRSCX Unique Styling

---

- New paint scheme incorporates the “#1” logo
- Based on the Screamin’ Eagle®/Vance & Hines NHRA Prostock V-Rod®



- 1250 cc engine
- Limited production of 1,400 units
- Laced front wheel

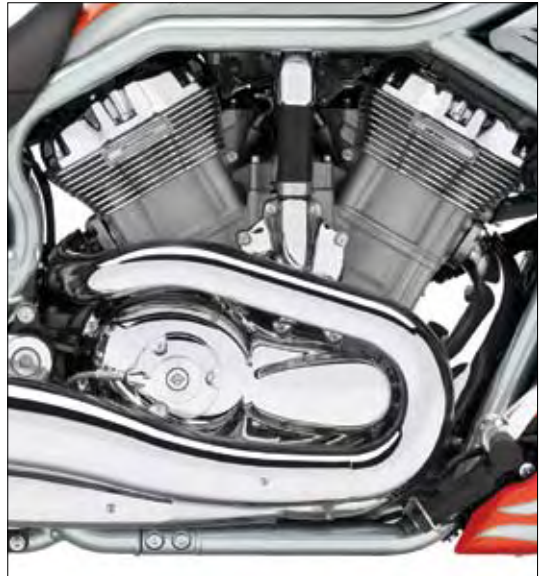

## Larger Battery

---

- Battery common with Dyna™ models except VRSCR
- Does not retrofit due to size and polarity of battery posts



---

## NEW Front Tires

---

- New tire tread design
- 207 Series Dunlap® front tire changed to 208 Series



## Radiator Trim Covers

---

- Similar trim cover as 2006 VRSCR models

### Important Service Note:

Retrofits with minor modifications to radiator cover.



## VRSCR Ergonomic Improvements

---

- Wider and higher handlebar
- Handlebar does not retrofit



## Front Electric Caddy

- Front fuse block contains starter relay, dual fan relay, ignition and battery fuse and one spare fuse
- 15-Amp fuses
- Data link is on right side, next to MAXI™ fuse

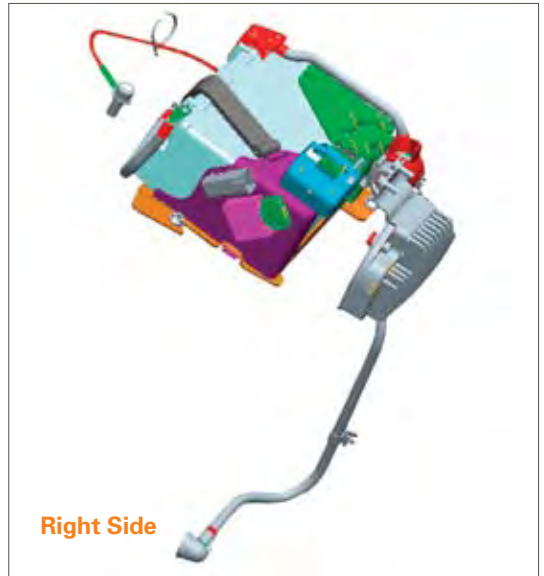

- New battery tray/electrical caddy accommodates starter solenoid
- Right- and left-hand controls, headlamp jumper harness and front turn signals located under left side

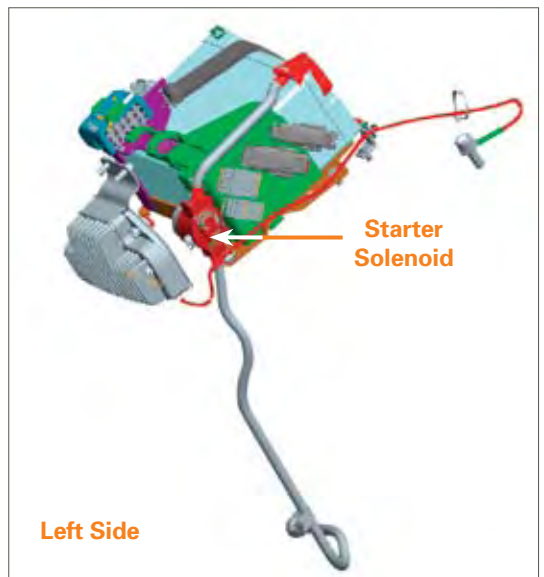

## Rear Electric Caddy

- Under passenger pillion
- Molex® connectors
- ECM located on rear caddy
- ECM, lights, security, spare fuse and accessory circuits located in rear fuse block



## NEW Wire Harness

- Harness has a new right-side branch that starts behind rear cylinder
- Rear coil and vehicle speed sensor leads are moved to the center of the motorcycle
- All VRSC™ motorcycles have Molex® connectors



Molex is a registered trademark of Molex Products Company.

**NEW****Exhaust Shield Retention**

- New hardware
- Fasteners do not retrofit to prior models
- New kit consists of new auxiliary volume and hardware to retrofit prior models

**Compensator Bowl**

- Wide compensator bowl accommodates new frame
- VRSCR compensator bowl remains unchanged



## **Split Rear Wheel Bearing**

---

- New bearing for models equipped with 240 mm tires
- CVO VRSC™ motorcycles used this bearing in 2006





# SPORTSTER® FAMILY



## The Sportster® Family Celebrates 50 Years

- 50th Anniversary 1200 model
- Limited production of 2,000
- Serialized nameplate on handlebar clamp
- Gold "50th" emblem on fuel tank
- New "H" silk-screening on side covers represents the cultural history of the Sportster® family
- Embroidered seat
- XL custom rear shocks



## NEW 883L Model

- Lowered 25.25 in. seat height
- New front and rear shocks
- New seat
- Parts retrofit
- Higher torque for 883 models
  - All 2007 XL motorcycles use "W" cams
  - 15% More torque at 2500 rpm
  - Requires 1200 mufflers for Japan market



## Redesigned Oil Pump

- Redesigned pump body, feed and scavenge gerotors
- New feed and scavenge porting
- Scavenge gerotors have larger diameter and are taller for more capacity
- Feed gerotors are thinner to accommodate taller scavenge gerotors in original pump body height but redesigned for no loss of capacity
- Internal parts do not interchange with earlier pumps
- Pump assembly will retrofit



## Electronic Sequential Port Fuel Injection (E.S.P.F.I.) for All XL Models

- 45 mm induction module for all models
- 15-Degree injectors
- New wiring harness with Molex® connectors
- Frame updated with new brackets to secure new wire harness
- Low fuel light
- 91 Octane for all 2007 Sportster® models



Molex is a registered trademark of Molex Products Company.

## Electronic Sequential Port Fuel Injection (E.S.P.F.I.) Sensors

- New TMAP sensor
  - Combined sensor MAP/IAT
  - Top of Induction Module (IM)
- IAC: top of IM
- TP sensor: left side of IM

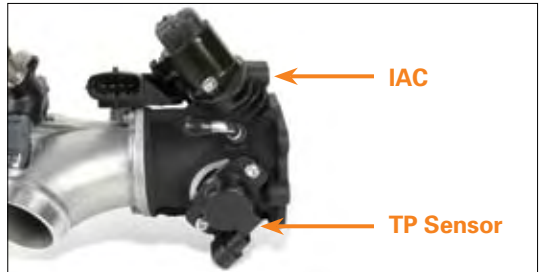
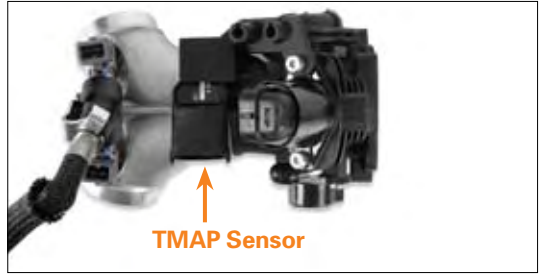

- Head temperature sensor is located in rear cylinder head similar to Buell® models
- Special tool available



## Oxygen Sensors

---

- Front and rear exhaust O<sub>2</sub> sensors
- Closed loop system like 2006 Dyna™ models



Front sensor shown

---

## Fuel Pump

- Mounted in new fuel tank
- Check Sportster® model Service Manual for pressure specifications
- Uses current fuel pressure gauge adapter (P/N HD-44061)



## Intake Flanges

- New intake flanges and fasteners
- Wider flanges allow for better fastener access
- Uses four hex bolts rather than allen bolts
- New cylinder heads to accommodate new flanges
  - 1200 Heads have changes to intake port and intake valve seat
  - No service procedure changes to new heads, only part number changes



## NEW Ignition Coils

- New coil mounting bracket
- New spark plug wires
- New primary and secondary resistance values
  - Check Sportster® model Electrical Diagnostics Manual for proper specifications



## NEW ECM and Fuse Location

- ECM is located underneath the seat on the rear fender
- Additional fuses are required
- New rear fenders and seats accommodate ECM



### **NEW Rocker Boxes**

- Rocker boxes have been changed to feature an improved sealing cavity
- New press-in-place gaskets
- Gaskets do not retrofit



### **32-Amp Charging System**

- Increased power to 32 amps from 22 amps to power the E.S.P.F.I. system
- Check Electrical Diagnostic Manual for proper specifications
- Rotor does retrofit
- New stator and voltage regulator do not retrofit



## Reduced-Effort Front Brake Lever

---

- DOT 4™ brake fluid is used in all 2007 XL motorcycles
- New calipers
- New master cylinders
- New brake lines
- Changes result in an 11% effort reduction for 883, 883L, 883C, 1200L and 1200C models
- Changes result in a 14% effort reduction for 883R and 1200R models
- New rear brake pads improve rear brake feel
- Rear brake pads do not retrofit



## NEW Handlebar Wiring

---

- Harnesses are lengthened by 2 in. to allow for easier changing of handlebars
- Extra harness is tucked into the electrical caddy underneath the fuel tank





H-D 07



**DYNA™ FAMILY**

## All Dyna™ Models

---

- All 2006 model year redesigns carry forward for 2007 Dyna™ models



## NEW Lower-Profile Transmission Cover

---

- Design common with the Softail® model
- New smaller J-hose vent and routing; new hose is shaped to accommodate HDI exhaust actuator
- Retrofits to 2006 Dyna™ models



## **NEW** Final Drive Gearing, Belt and Belt Guard Change

- Final drive gearing is matched to optimize the new Twin Cam 96™ powertrain
- New rear sprockets
  - HDI and domestic models: 66-tooth rear sprocket/ 131-tooth drive belt
  - H-D Japan models only: 64-tooth rear sprocket/ 130-tooth belt



FXD Dyna™ Super Glide® model

## **NEW** 40-Amp Charging System

- Three-phase, 40-amp output charging system OE (Dyna™ and Softail® models)
- Consists of:
  - New 12-magnet rotor
  - New stator
  - Stator and rotor assembly retrofits to 2006 Dyna™ models



## Transmission Shift Detent and Roller Change

- Shift detent arm, spring and roller design change
- Part number revisions to "A" suffix
- 2007 Transmission detent assembly retrofits to post-recall 2006 Dyna™ motorcycles
- This assembly is sold as a kit for 2006 Dyna™ models



## NEW Steering Head Adjustment Access Area

- Notched access area provides improved access for servicing
- Notch allows service procedure to be common with Softail® and Touring models



### FXDBI Dyna™ Street Bob™ and FXDI Dyna™ Super Glide® Models

- New stainless steel rear fender supports
- Brushed stainless steel covers on FXDB model
- Recommended cosmetic care product: Harley-Davidson® Bright Chrome Cleaner (P/N 94683-99)



- Polished stainless steel covers on FXD model
- Recommended cosmetic care product: Harley-Davidson® Bright Metal Polish (P/N 99725-89)

#### Important Service Note:

Surface care products for new finishes are in the Dyna™ model Owner's Manual.



**NEW on FXDC Model**

- Based on 35th Anniversary Super Glide® model



- Unique model features:
  - Tank trim and cloisonné
  - Ribbed seat
  - Battery cover trim
  - Handlebars and front brake line
  - Electrical caddy cover trim
  - Leather tank panel with the "#1" logo





# SOFTAIL<sup>®</sup> FAMILY

### **NEW Twin Cam 96B™ Engine Balancers**

---

- New one-piece balancer support bracket
- New bearing installer/removal tool required for service



### **FLSTF and FX "Bobtail" Models - New Tire**

---

- 200 mm rear tire with new tread design





**NEW for FX Softail® Models**

- New handlebars, risers and clamps

**UK Dual-Face  
Speedometer Change**

- New speedometer face reads up to 130 mph (200 km/h)



Touring model example shown

## 25 mm Wheel Bearings and Axle

- All Softail® models, except the Springer® model, receive 25 mm front wheel bearings



- New front axle



## Fat Boy® Model Front End Changes

---

- New-style handlebars and risers
- Internal handlebar wiring



- New front panel/nacelle



### **Extended Rear Brake Control and Footrest Mounts on FX "Bobtail" Models**

---

- Right side components extended outward approximately 1 in.
- Allows for more stretched-out rider comfort
- Rear brake pedal styling improved



### **NEW Three Electric Caddys**

---

- One caddy is located under fuel tank



**NEW****Three Electric Caddys** (cont.)

- A second caddy is behind the voltage regulator



- A third caddy is under the rear fender cover



## Rear Fenders

---

- Sound-dampening material added to fender



## NEW Four-Hole Fender Supports on FLSTN

---

- Allows more P&A accessory opportunities





# TOURING FAMILY

## NEW Idle Temperature Management Download Option

- For prolonged engine idle conditions
- In hot riding conditions, an optional dealer-enabled engine calibration is available
- New download cuts combustion to rear cylinder
- Engine must be at certain operating temperature
- Vehicle must be at idle and not moving to activate
- Exhaust changes tone with only front cylinder firing
- Exhaust may have slightly different odor
- Installation of download is free one time only (under warranty)
- Removal of download is free one time only (under warranty)
- Prior systems have been removed for 2007 models





### Sidecar Brake Reservoir

- Relocated in order to provide necessary clearance for the O<sub>2</sub> sensors
- Mounts to the outside of the front frame support bracket



- New design



## Shift Lever and Floorboard Changes

- New shift lever, left-hand rider floorboard supports and passenger floorboard supports
- Changes accommodate additional clearance necessary due to new engine, transmission and primary drive
- Shift lever retrofits to prior models but pre-2007 levers do not fit new Touring motorcycles
- New board mounts retrofit to prior motorcycles
- Old board mounts do not retrofit to 2007 models



## Frame and Swingarm Changes

- Frame, swingarm and engine mounts accommodate new engine
- Swingarm forging moved to the rear
- New swingarm support brackets (end caps)
- New forged, front engine mount bracket clears new crankcase
- Swingarm mounts do not retrofit
- 2007 Touring frame does not retrofit to prior models



## Jiffy Stand Change

---

- Touring motorcycles come with a new Jiffy stand to accommodate changes from new engine
- New bumper
- Mount has changed



## Saddlebag Supports

---

- New cast zinc I-brackets and end bullets for saddlebags
- New brackets appear the same but have a smoother finish on all sides
- Reduces scratching of saddlebags when removing



### Twin Cam 103™ cu. in. Engine for Police Models

- 1690 cc CVO engine
- 9.6:1 Compression ratio
- Unique calibration
- ABS and Harley-Davidson® Smart Security System optional equipment
- Unique clutch spring
- Catalyst mufflers
- Active intake and exhaust on HDI Police motorcycles



### Sidecars for Police Motorcycles

- Police Touring motorcycles with ABS do not accept a sidecar
- Hydraulic line routing on the right side interferes

#### Important Service Note:

Police and Touring motorcycles equipped with sidecars will not accommodate an oil cooler.

Oil cooler assembly needs to be removed before sidecar installation.



## **NEW Handlebar Clamps**

- Handlebar control clamps are modified improving clearance for wire harness

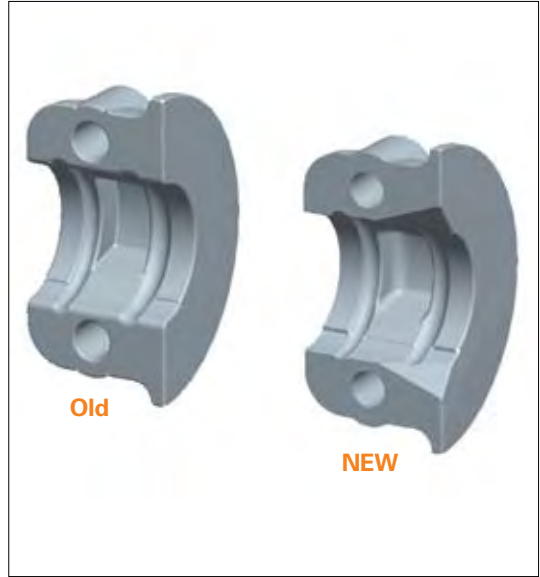

## **Front Electrical Caddy**

- New caddy mounts under voltage regulator retaining connector for crank position sensor

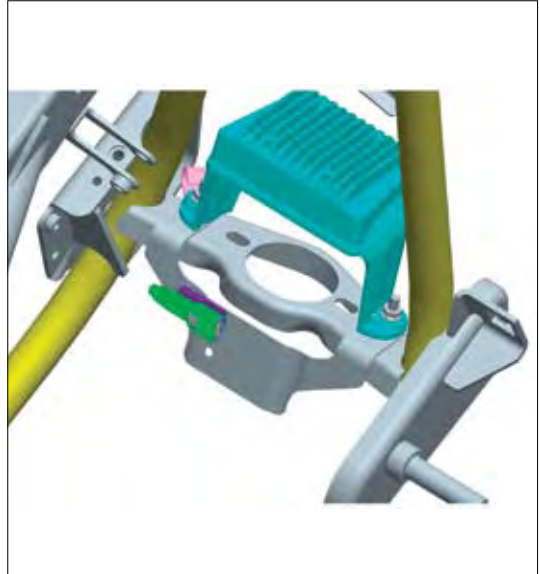



# CVO FAMILY

## NEW CVO Engine

- 110 cu. in. 1800 cc engine
- 9.3:1 Compression ratio
- New heads, combustion chamber, ports and intake valve
- 255 Cams
- 4 in. bore
- 110-Scripted derby cover and air cleaner insert
- Syn 3 engine oil
- 1.4 Kw starter



- 4.375 (111.13 mm) stroke; same as OE engines
- ACR solenoids to ease start-up – located in each cylinder head
- Torque range of 105-115 ft. lbs. measured at crankshaft (depending on model)
- All CVO models have hydraulic clutch – DOT 4™

### Important Service Note:

Do not use chrome polish on the new flush-mount LED fuel gauge (FXSTSSE, FLHRSE<sup>3</sup> and FXDSE all feature this gauge).



**FLHTCUSE<sup>2</sup>**  
**Screamin' Eagle<sup>®</sup>**  
**Ultra Classic<sup>®</sup> Electra Glide<sup>®</sup>**

- Heated seat and grips
- Relocated intercom plug integrated with left rear speaker pod
- Multifunctional switch for cruise control and spotlights
- Light smoked short windshield
- Adjustable passenger footboards
- Power locks on Tour-Pak<sup>®</sup> and bags are dash controlled



- Harley-Davidson<sup>®</sup> Smart Security System (H-DSSS) with self-powered alarm
- XM Satellite Radio (three months of service) and amplifier, except HDI
- Advanced audio integrated navigation system
- Hand/foot controls, footboards and highway pegs are from Ironside Collection
- Paint with Pearl highlights:
  - Light Candy Cherry with Black Ice
  - Lightning Blue Pearl with Midnight Pearl
  - Black Ice with Electric Orange





## FLHRSE<sup>3</sup> Screamin' Eagle<sup>®</sup> Road King<sup>®</sup>

- Flush-mount gas cap and fuel gauge
- Oil cooler and chrome cover
- Leather saddlebags and seat with chrome trim and flame insert; detachable rider and passenger backrests; also available from P&A, optional matching leather Tour-Pak<sup>®</sup> with flame insert
- Radial tires:  
18 in. x 3.5 in. front wheel;  
17 in. x 4.5 in. rear wheel;  
130 mm front and 170 mm rear; tire pressure change to 36 psi front/38 psi rear (solo rider); 38 psi front/42 psi rear (rider and passenger)
- Custom spun-metal faced speedometer/tachometer combination
- Dual halogen headlamp
- H-DSSS with self-powered alarm
- Dark smoked mini wind deflector
- Lowered P&A shocks
- 1.25 in. chrome handlebar with internal wiring
- Floorboards, passenger pegs, highway pegs and hand/foot controls are from Ironside Collection
- Fat Boy<sup>®</sup> front fender; wide rear fender, swingarm and rear axle
- Paint with leafing graphics and marble accents:
  - Razor Red with Burnt Gold
  - Candy Cobalt with Pale Gold
  - Black Ice with Pewter



## FXSTSSE Screamin' Eagle® Softail® Springer®

- 1.25 in. chrome handlebar with internal wiring
- Chrome forward controls
- Chrome handlebar risers
- Mini-tach and new chrome tach mounts
- Revolver chrome 10-spoke forged-aluminum wheels
- Revolver chrome 66-tooth sprocket
- Revolver brake rotors
- 200 mm rear tire
- New tri-bar LED tail lamp
- Low-profile, chrome fuel tank console



- Hand/foot controls and footpegs are from new Centerline Collection
- Flush-mount fuel cap and gauge
- H-DSSS with self-powered alarm
- Custom leather two-up seat with ribbed insert
- Color-matched frame, swingarm, rigid forks, upper triple clamp, oil tank, frame inserts, seat post and muffler support brackets
- Tribal Flame paint:
  - Abyss Blue with Blue Pearl
  - Canyon Copper with Candy Red
  - Amarillo Gold with Candy Tangerine



## FXDSE Screamin' Eagle® Dyna™

- Custom spun-aluminum gauge package
- Extended headlamp trim ring
- Polished stainless steel rear brake push rod and shifter rod
- Braided line package
- Chrome package
- Inverted front forks
- Covered low rear shocks with hand-adjust preload
- Custom 1.25 in. handlebar
- Knurled chrome handgrips and footpegs
- Rolled-back front fender



- Color-matched frame, battery box, electrical panel cover, coil cover and chin spoiler
- 170 mm rear tire
- Custom bucket seat with perforated inserts
- Full-length fuel tank console
- Flush-mount, aircraft-style gas cap
- Layback license plate
- Paint options:
  - Silver Rush and Midnight Black
  - Inferno Red and Desert Black
  - Twilight Blue with Ice Blue, Granite and Ice Blue Pearl



BUELL 07



**BUELL<sup>®</sup> FAMILY**

### **XB Firebolt® Models**

---

- New wheel colors
- New bodywork colors
- Tinted windscreens



---

### **XB Lightning® Model**

---

- New color combinations available for wheels and bodywork
- CityX seat has new cover material



## Ulysses® Models

---

- New P&A camouflage bodywork
- Ulysses® seat has new cover material
- 1.3 in. lower seat height – laden
- 2.2 in. lower seat height – unladen
- Seat does retrofit
- Seat is reshaped



---

## Buell® Blast®

---

- New Arctic White color added



### **NEW Inner Rocker Cover with Press-in-Place Gasket**

- Redesigned press-in-place gasket
- Inner rocker cover has been redesigned to accommodate new gasket design
- Inner rocker cover fits previous XB models (P/N 17598-07)

#### **Important Service Note:**

Do not stretch gasket while installing; position gasket in cover and use top rocker cover to press gasket into position.

Gasket kits include both early and new gaskets.



### **NEW Rocker Cover/ Cylinder Head Gasket**

- New design has coated gasket

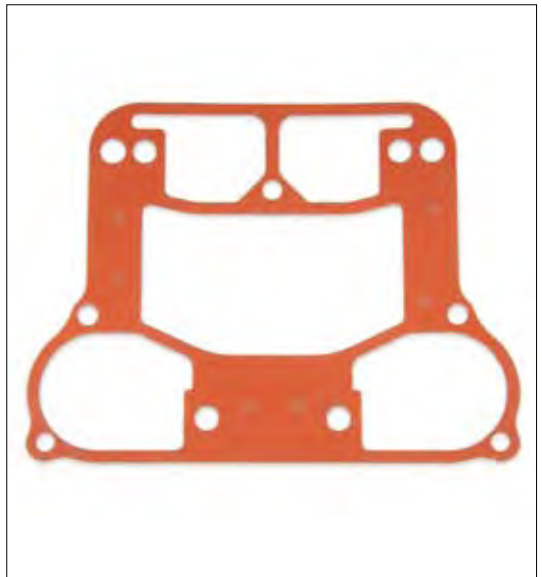

### NEW Throttle Position Sensor (TPS)

- Identified by one or two orange paint dots on top of TPS
- New TPS rotor tangs are at 1 and 7 o'clock positions
- Old-style TPS rotor tangs are at 4 and 10 o'clock positions
- TPS sensors do not interchange
- New TPS (P/N PO279.3AA)
- Old TPS (P/N 29537-99Y)



### NEW Throttle Body Manifold

- New throttle shaft TPS engagement pins oriented at 6 and 12 o'clock positions
- Old-style engagement pins are orientated at 2 and 8 o'clock positions





## **NEW Primary Chain Cover**

- Additional material added to the casting at the primary adjuster shoe screw support



## **Redesigned Oil Pump**

- Redesigned pump body, feed and scavenge gerotors
- New feed and scavenge porting
- Scavenge gerotors have larger diameter and are taller for more capacity
- Feed gerotors are thinner to accommodate taller scavenge gerotors in original pump body height, but redesigned for no capacity loss
- Internal parts do not interchange with earlier pumps
- Pump assembly fits earlier XB models



### **Additional Holes in Airbox Functional Cover**

---

- Revised calibration for new airbox



---

### **Tire Changes**

---

- Pirelli® Diablo tires except on XB9SX and XB12X (Ulysses®)
- Pirelli® Scorpion Sync tires used on XB9SX and XB12X (Ulysses®)



## Ulysses® Seat Limiter

---

- Separates underseat components from bottom-of-seat pan



## Ulysses® Progressive Rate Fork Spring

---

- Provides wider range of smooth progressive control of front suspension over long fork travel
- Revised fork service specifications
- Does retrofit and requires the new front and rear 2007 suspension specifications





**SCREAMIN' EAGLE®**

### Big Bore Stage 1 Kit 103 cu. in.

- Increase displacement from 96 in. to 103 in. (1584 cc to 1690 cc)
- Big bore cylinders and pistons
- High-flow A/C kit
- 50-State street legal
- Digital Technician calibration



### Big Bore Stage 2 Kit 103 cu. in.

- Increase displacement from 96 in. to 103 in. (1584 cc to 1690 cc)
- Big bore cylinders and pistons
- High-flow A/C kit
- 255 Cams
- Catalyst exhaust
- 50-State street legal
- Digital Technician calibration



## 110 cu. in. Stage 1 Kit

- Increase displacement from 96 in. to 110 in. (1584 cc to 1800 cc)
- 255 Cams produce low rpm torque
- 4 in. bore cylinders and forged pistons
- 9.3:1 Compression ratio
- 50-State street legal
- Digital Technician calibration



- Cylinder heads have many features and functions
  - New combustion chamber
  - Port cores and intake valve
  - Automatic compression release
- Dyna™ and Softail® models have a high-flow A/C kit
- Touring kit has special high-flow A/C element



## **Screamin' Eagle® Exhaust**

- New street performance exhaust systems are street legal for 2007 models
- Each exhaust system is designed to optimize the Twin Cam 96™ engine performance and provide premium sound and style while complying with noise regulations



## **E.S.P.F.I. Calibrations**

- Calibration cartridges discontinued early in the 2007 model year
- All street-legal calibrations for 1995-2007 models are available on Digital Technician
- Race calibrations for 1995-2006 models are available on Digital Technician
- Race calibrations for 2007 models require Screamin' Eagle® Race Tuner
- All race calibrations continue to be available in Screamin' Eagle® Race Tuner



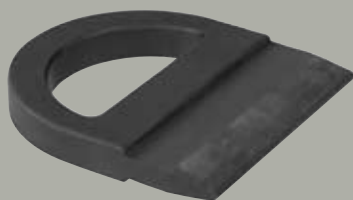

# SERVICE AND TOOLS



**NEW Calibrations Search - h-dnet.com**

- Customized to all models worldwide
- Active screen capture help
- Calibration-specific selection
- Revised search buttons
- Reverse lookup feature with calibration I.D. #



**Several P&A Cast Wheels Sold Differently**

- Bearings and sleeves are not installed in the wheels from the factory
- Bearings and sleeves are ordered separately
- Bearings and sleeves offered as a kit
- Softail® front wheels, 19 in. and 21 in. front wheels, and 17 in. x 4.5 in. wheels are affected



## VRSCDX Wheels

---

- 240 mm tires
- Black painted wheels need to be serviced with caution as cosmetic damage can occur if proper procedures are not used



## NEW XL Fuel Lines

---

- Fuel lines may appear to be kinked upon delivery until ignition is turned on to expand the line



## Crankshaft Rotating Wrench

---

- P/N HD-48283
- Made for new splines on crankshaft
- Used on 2006 Dyna™ models and 2007 Twin Cam 96™ engines
- Crankshaft Rotating Wrench is not part of the 2007 Essential Tool Kit



---

## Essential Tools

---

- **Wheel Bearing Collet**
  - P/N HD-44060-10
  - Added to Essential Tool Kit
  - Collet added to the Wheel Bearing Kit (P/N HD-44060-A)
  - Removes 25 mm wheel bearings featured on Softail® front wheels
  - Springer® models continue with 1 in. wheel bearings/collets



**Essential Tools** (cont.)**• Vehicle Alignment Tools**

- P/N HD-46247-1  
P/N HD-46247-2
- New pivot shaft alignment blocks for 2007 FL models
- Frame changes made blocks necessary

**• Triple Trees Wedge for VRSCR**

- P/N HD-48287
- Spreads clamp to prevent damaging painted fork tubes during servicing
- Two wedges come in the kit



## Essential Tools (cont.)

### • Short Primary Drive Locking Tool

- P/N HD-48219
- Locks primary drive for removal/installation of compensating sprocket assembly and clutch hub
- Touring models only

### Important Service Note:

Tech Tip #212 explains primary drive locking tool usage for 2006 Dyna™ models, which applies to this new tool as well.



### • Head Temperature Sensor Socket for XL Models

- P/N HD-48116
- Used to remove/install head temperature sensors from the rear cylinder of XL models



**Essential Tools** (cont.)**• O<sub>2</sub> Sensor Socket**

- P/N HD-48262
- Used on all H-D models

**• Sprocket Shaft Adapter and Collar**

- P/N HD-97225-1  
P/N HD-97225-2
- Adapts the sprocket shaft bearing installer tool to P/N HD-497225-55C for servicing new Twin Cam 96™ and 2006 Dyna™ engines
- Collar is used to install the bearing inner race



## Essential Tools (cont.)

### • Sprocket Shaft Seal Installer

- P/N HD-39361B
- Allows the simultaneous installation of the sprocket shaft seal and spacer
- Installing both parts at the same time ensures the seal is protected



### • Balancer Bearing Installer for Softail® Models

- P/N HD-48309
- Installs the new bearing and balancer for the Twin Cam 96B™ engine
- New bearing must be pressed onto balancer before pressing assembly into case
- Case must be supported when pressing in balancer/bearing assembly



## Essential Tools (cont.)

- **Twin Cam 96B™ Outboard Balancer Bearing Remover/ Installer**

- P/N HD-48474
- Removes and installs bearings from the chain guide support plate



- **Twin Cam 96B™ Balancer Puller**

- P/N HD-48457
- Puller extracts the Twin Cam 96B™ balancer/ bearing assembly
- Plate is reversible for front and rear balancers





**Essential Tools** (cont.)**• Terminal Remover**

- P/N HD-48114
- Removes socket and pin terminals from Molex® connectors
- Used on all models

**Important Service Note:**

Refer to the instruction sheet to prevent damage.

**• Electrical Crimp Tool**

- P/N HD-48119
- Crimps Molex® terminals



Molex is a registered trademark of Molex Products Company.

## Essential Tools (cont.)

- **TMAP Sensor Pin Probes**

- P/N HD-41404-15
- New probes required for electrical diagnostics on TMAP sensor terminals on XL models
- Probes are a light orange color



- **H-DSSS Antenna Pin Probes**

- P/N HD-41404-20
- Used on all models with security systems
- Probes are a light blue color



- **Barcode Reader for Security Systems**

- P/N HD-48263
- Functionality is enabled through Digital Technician Phase 19 software
- Assigns fobs during PDI
- Increases accuracy and efficiency
- USB connectivity
- Optional fob assignment can be input by reading the 24-character security ID behind fob cover
- 24-Character security ID matches the system ID for the HFSM



## Essential Tools (cont.)

---

### • USB Hub

- P/N HD-44750-15
- CF27 and CF28 laptops do not supply enough power through the USB port to properly power the Barcode Reader
- 4-Port USB 2.0 hub with AC power supply
- Permits connection of multiple devices such as USB Barcode Reader, USB Mouse and USB Printer



## Authorization Protocol

---

- Authorization numbers are not a guarantee for payment
- Revised Warranty Manual on [h-dnet.com](http://h-dnet.com)
- Authorization protocol not applicable if under initial care

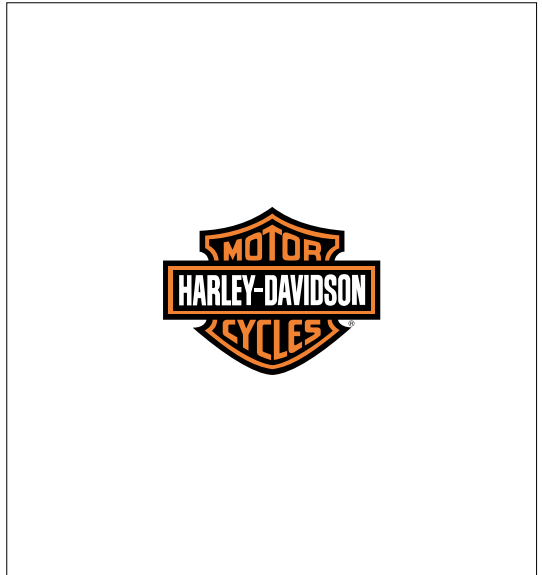

## NEW Digital Technician Service Procedures

- Harley-Davidson® Smart Security System (H-DSSS) set-up
- Scan barcode on fob packaging
- Test fob functionality
- Enable security by entering PIN # once fobs are assigned
- Disable security during service at dealership



## H-DSSS ID Information

- System ID displays fob assignment



### H-DSSS Diagnostics

- Clutch interlock switch and neutral indicator functionality displayed in data items screen



### Digital Technician Calibrations

- Phase 19 software has OE, performance street legal and off-road race calibrations for 2006 and earlier motorcycles
- 2007 motorcycles can be calibrated with OE and performance street legal downloads
- Off-road race calibrations for 2007 motorcycles require the Screamin' Eagle® Race Tuner



## Performance - Legal

### Important Service Note:

Tech Tip #236 explains the differences between legal and race calibrations.



## Compliant Conditions and Cautions



**Compliant Conditions and Cautions** (cont.)

---



**Performance Warning Screen**  
(Race Use Only!)

---



## Vehicle Recalibration Report

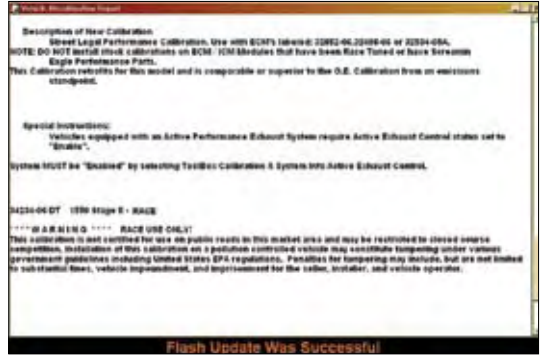

## Digital Technician Active Exhaust Test

- Cycles active exhaust actuator and monitors feedback circuit





## Fork Oil and Spark Plug Service

- Additional service info:
  - Fork oil service interval extended to 50,000 miles (80,000 km)
  - Spark plug inspection service interval or replacement extended to 20,000 miles (32,000 km)



## Formula+ Primary Levels

- All FL Touring Big Twin models primary drives require 45 oz. dry capacity and 38 oz. wet capacity of Formula+
- All Softail® and Dyna™ models require 32 oz. wet and dry capacity of Formula+
- There is no longer a visual inspection
- Primary service intervals: increased service to every 10,000 miles (16,000 km) from 5,000 miles (8,000 km)
- Transmission Formula+ change interval increased to 20,000 miles (32,000 km) from 10,000 miles (16,000 km)



## Advanced Audio System Website - [Harley-Davidson.com](http://Harley-Davidson.com)

- Inside the motorcycles/2006/ Touring section
- New listing of compatible cell phones
- Updated sound system downloads
- Burn CD's from site at low speed for no charge sound system updating
- Tech Tip #243 is a helpful review



## Initial Care Programs

- **2007 Twin Cam 96™ Powertrain**
  - Warranty pre-authorization from Technical Service required for any Twin Cam 96" powertrain repair
  - P&A and Screamin' Eagle® performance parts installation does not require authorization 7/15/06 through 12/22/06
- **2007 XL Sportster® Models**
  - Fuel pumps, ECM and fuel lines require pre-authorization for replacement under warranty
  - Powertrain repairs require pre-authorization 7/15/06 through 10/13/06



## 2007 Model Year Drive Belt Tension Specifications

Check belt deflection at the loosest spot on the belt with the transmission in neutral and the motorcycle at ambient temperature. Use belt tension gauge (P/N H-D-35381A) and apply 10 lbs. of force at the midpoint of the bottom strand. 2007 belt deflection should be as follows:

MODEL	VEHICLE ORIENTATION	BELT DEFLECTION (IN.)
FLHT, FLHR, FLHTCU, FLHTC, FLHRC, FLTR	Vehicle upright with rear wheel in air or on Jiffy stand without rider or luggage	3/8 – 7/16
FLHRS, FLHX	Vehicle upright with rear wheel in air or on Jiffy stand without rider or luggage	1/4 – 5/16

**TABLE 1:** FLT Belt Deflection Specifications

MODEL	VEHICLE ORIENTATION	BELT DEFLECTION (IN.)
FXD, FXDWG, FXDC	Vehicle upright with rear wheel in air	1/2 – 9/16
FXD, FXDWG, FXDC	On Jiffy stand without rider or luggage	5/16 – 3/8
FXDL, FXDB	Vehicle upright with rear wheel in air	5/16 – 3/8
FXDL, FXDB	On Jiffy stand without rider or luggage	1/4 – 5/16

**TABLE 2:** Dyna™ Belt Deflection Specifications



**2007 Model Year Drive Belt Tension Specifications** (cont.)

MODEL	VEHICLE ORIENTATION	BELT DEFLECTION (IN.)
FLSTN, FXSTD	Vehicle upright with rear wheel in air	5/16 – 3/8
FLSTN, FXSTD	On Jiffy stand without rider or luggage	1/4 – 5/16
FLST, FLSTC, FLSTSC, FXSTC, FLSTF, FXST, FXSTB, FXSTS	Vehicle upright with rear wheel in air or on Jiffy stand without rider or luggage	11/16 – 3/4
FLST, FLSTC, FLSTSC, FXSTC, FLSTF, FXST, FXSTB, FXSTS	On Jiffy stand without rider or luggage	9/16 – 5/8

**TABLE 3:** Softail® Belt Deflection Specifications

MODEL	VEHICLE ORIENTATION	BELT DEFLECTION (IN.)
XL883 STD, XL883R, XL1200R	Vehicle upright with rear wheel in air or on Jiffy stand without rider or luggage	9/16 – 5/8
XL883C, XL1200C, XL883L, XL1200L	Vehicle upright with rear wheel in air or on Jiffy stand without rider or luggage	1/4 – 5/16

**TABLE 4:** XL Belt Deflection Specifications

